

DRUM LOUVER PLENUM-DIFFUSER

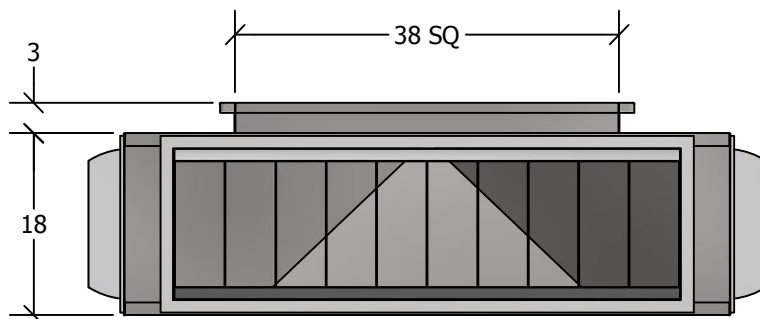

STANDARD FEATURES

1. G-90 Galvanized Steel Construction.
2. Turning Vanes in Each Quadrant.
3. 1" 1-1/2 lb. Duct Liner.
4. Vertical and Horizontal Adjustable Drum Louver.
5. Fully Assembled
6. TDC Duct Connections Provided.
7. 3/8" Threaded Inserts for Mounting Available.
8. Engineered Curb and Duct Packages Available.

NOM CFM 12,000	MODEL NO DLPD3 5015-30	WEIGHT 281 LBS
0° DEFLECTION		
THROW 82-142	P.D. .119	NC 37
30° DEFLECTION		
THROW 56-118	P.D. .2142	NC 45

QTY TAG

JOB NAME

CURBS PLUS, INC.
www.curbs-plus.com